



ΕΡΓΑΣΤΗΡΙΟ ΜΙΚΡΟΕΛΕΓΚΤΩΝ

ΑΤΜΕΛ AVR

ΠΟΡΛΙΔΑΣ ΔΗΜΗΤΡΙΟΣ



ΣΚΟΠΟΣ ΤΟΥ ΕΡΓΑΣΤΗΡΙΟΥ

- **Ερμηνεία της αρχιτεκτονικής των μικροελεγκτών**
 - ATMEL AVR mega/tiny 8-bit, AVR XMEGA 8/16-bit, AVR UC3 32-bit
 - ST STM32Fxxx 32-bit
- **Αναγνώριση προγραμμάτων Integrated Development Environment (IDE)**
 - Atmel Studio
 - Arduino IDE
 - System Workbench for STM32 (Eclipse), STM32CubeMX
- **Εξοικείωση με γλώσσα προγραμματισμού Embedded C (MCU GCC)**
 - avr-gcc, avr32-gcc
 - arm-none-eabi-gcc
- **Αναγνώριση υλικού μικροελεγκτών και περιφερειακών συσκευών**
 - AVR Minimum System Board
 - Arduino nano/mini/uno/mega
 - Maple mini
 - STM32 Minimum System Development Board
 - Programmers/Keyboards/Displays/Sensors/RS232 modules
- **Εξοικείωση με το υλικό σε επίπεδο αναπτυξιακών και πρωτοτύπων**
 - Χρήση πληκτρολογίου – οθόνης
 - Μετρήσεις τάσης, θερμοκρασίας
 - Επικοινωνία με ψηφιακούς αισθητήρες, επικοινωνία μικροελεγκτών, επικοινωνία με Η/Υ

ΕΞΕΛΙΞΗ ΤΩΝ ΕΠΕΞΕΡΓΑΣΤΩΝ

- `70 logic circuits
 - `80 PC
 - `90 MCU
 - `00 SOC

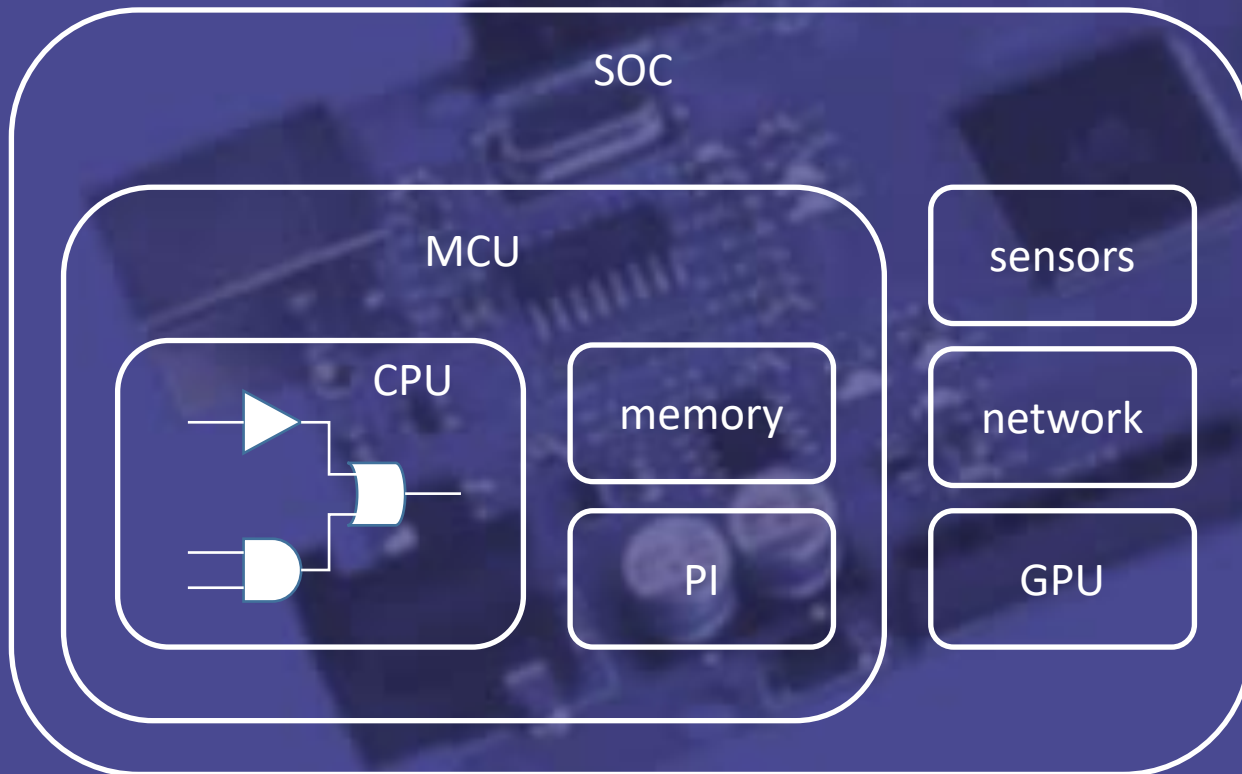

2021

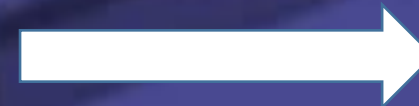

Apple A14 Bionic
Snapdragon 888
Exynos 2100
Kirin 9000

ARDUINO

Arduino Development Board

- MICRO/PRO/UNO/LilyPad (ATmega328)
- MEGA 2560 (ATmega2560)
- ZERO (ATSAMD21G18, 32-Bit ARM)
- 101 (Intel Curie: x86 Quark, 32-bit ARC)

USB ISP (USBasp with adapter)

- Program Bootloader

Arduino IDE

- Free download: <https://www.arduino.cc/>

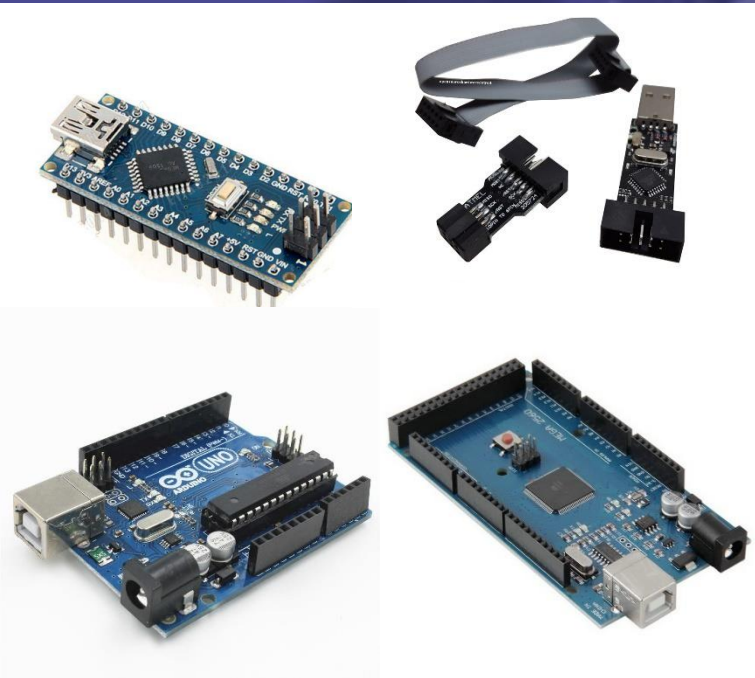
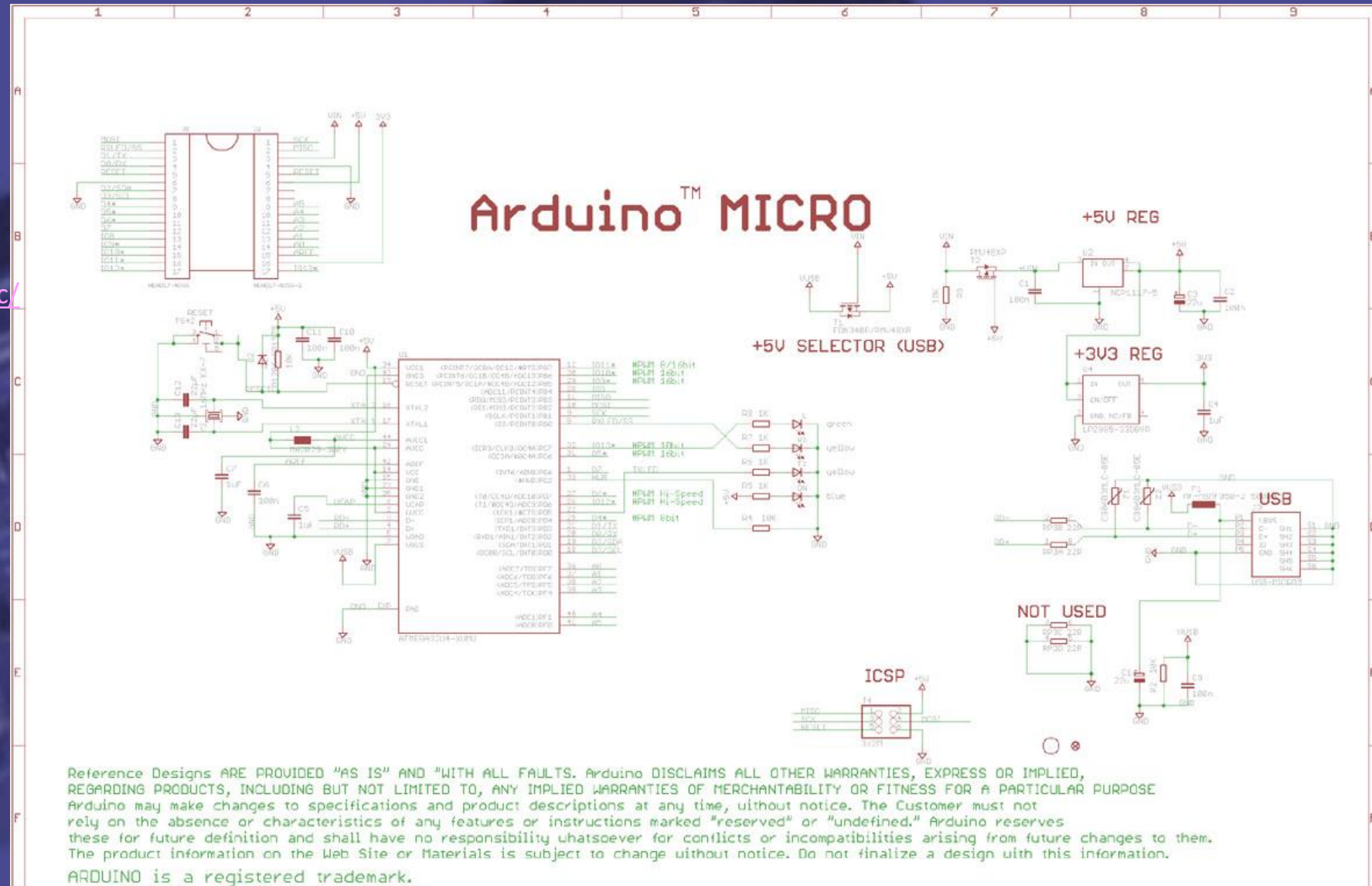

STM32

ST Development Board

- Nucleo32/64/144 (STM32F3xx/4xx/7xx)
- Discovery (STM32F4xx)
- Eval

Independent designers (STM32F103)

- Minimum System Development Board
- Maple mini (Arduino IDE compatible)

ST-Link V2 (SWD, JTAG)

USB to RS232 module

STM32CubeMX

- Free download: <http://www.st.com/>

System Workbench for STM32 (Eclipse)

- Free download: <http://www.openstm32.org/>

Demonstrator GUI

- Free download: <http://www.st.com/>

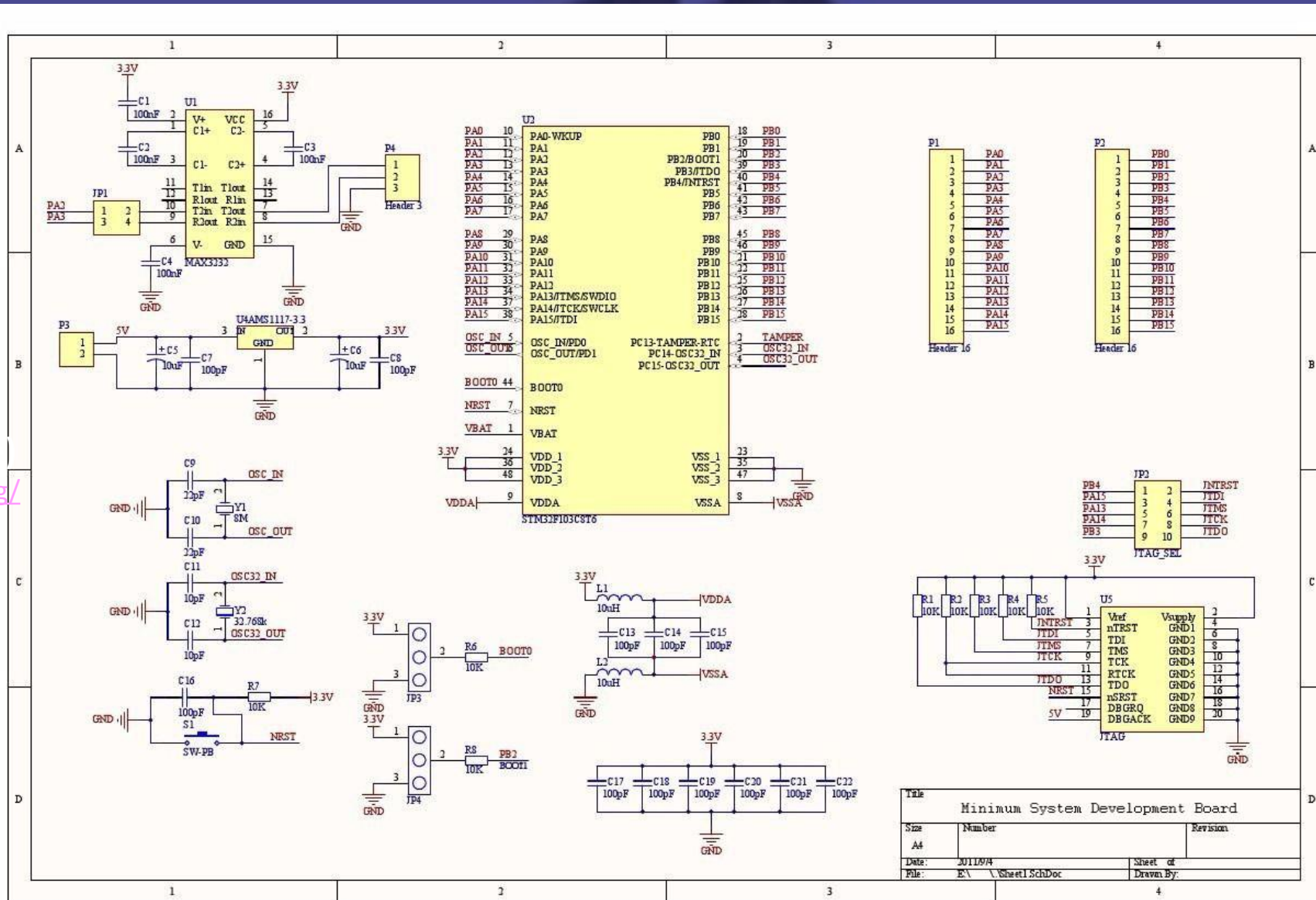
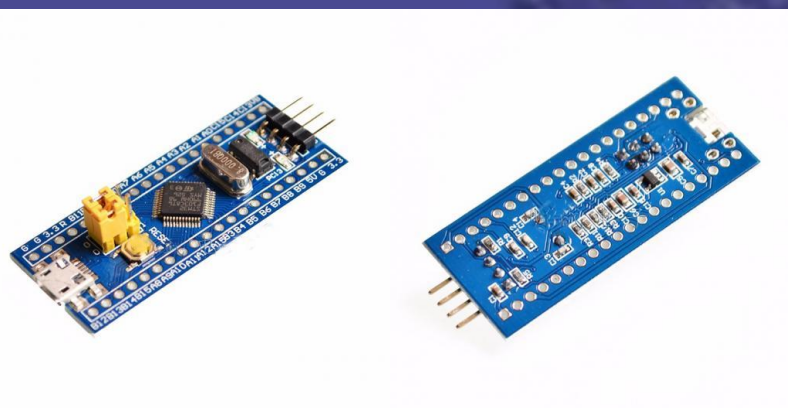

Raspberry Pi 3

- Quad Core 1.2GHz Broadcom BCM2837 64bit
- 1GB RAM
- Micro SD card slot
- 4 USB 2 ports, Full size HDMI
- CSI camera & DSI display ports
- Micro USB power source up to 2.5A
- 4 Pole stereo output and composite video port
- <https://www.raspberrypi.org/>

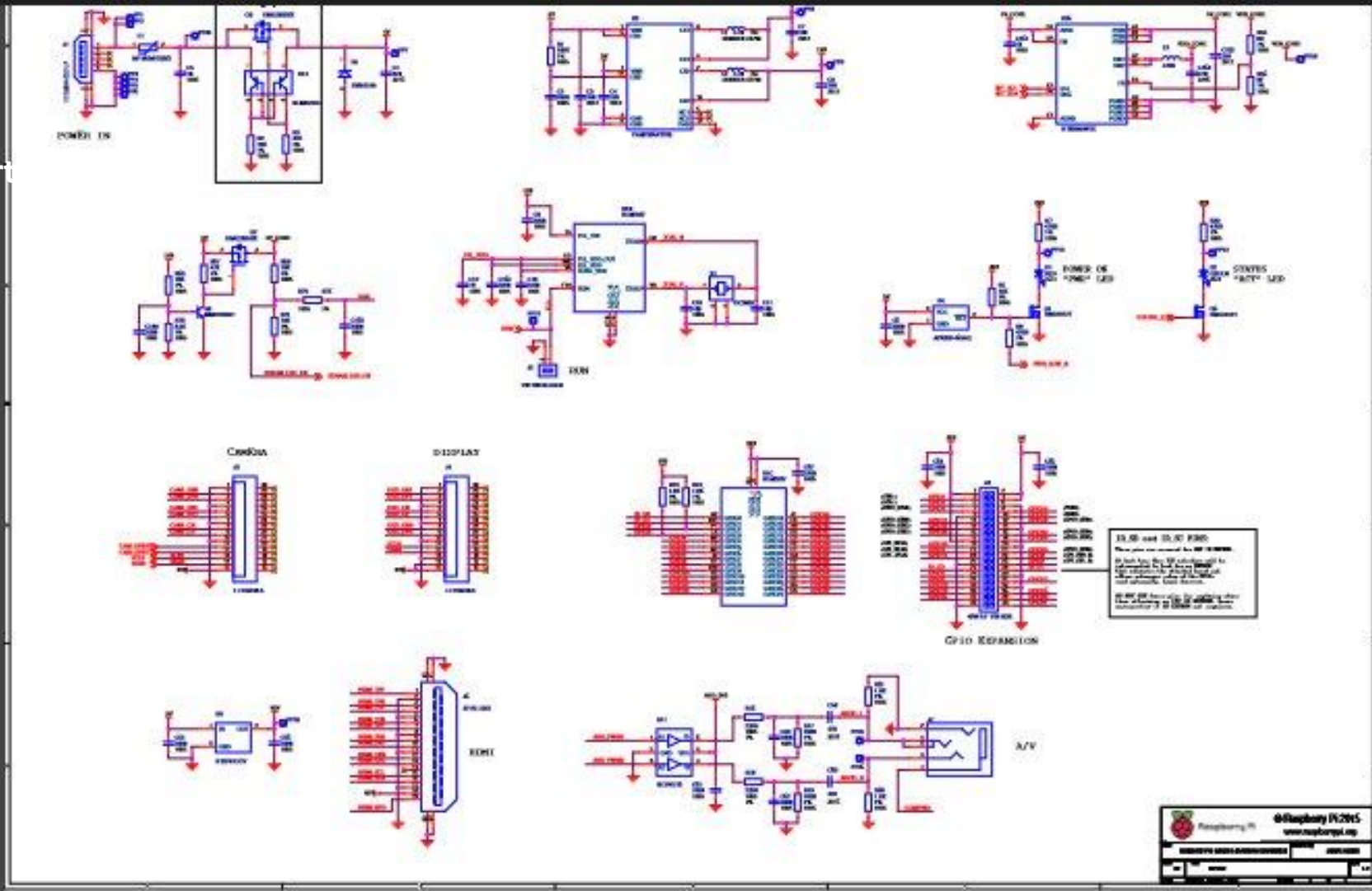

Peripherals

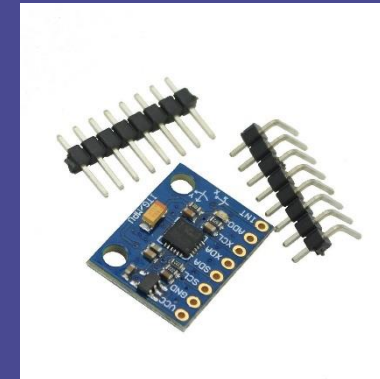
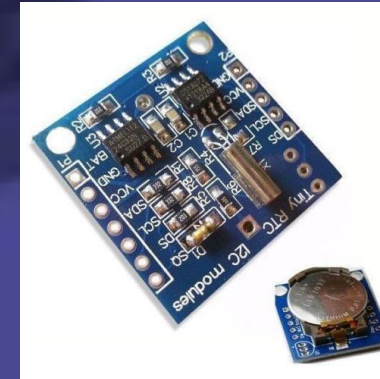
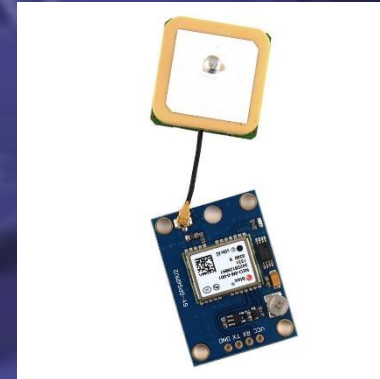
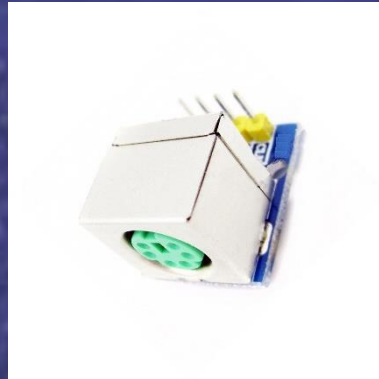
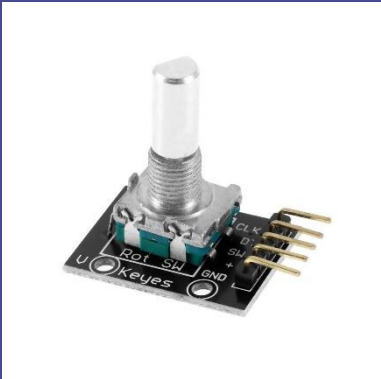
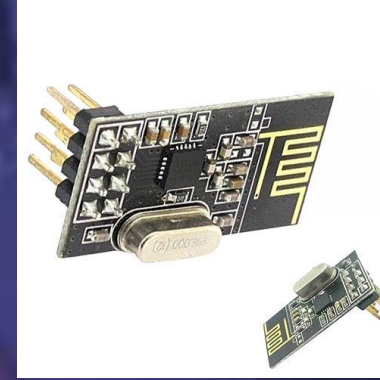
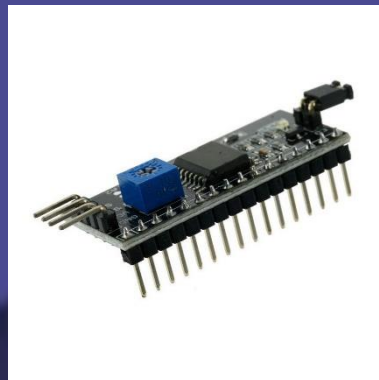
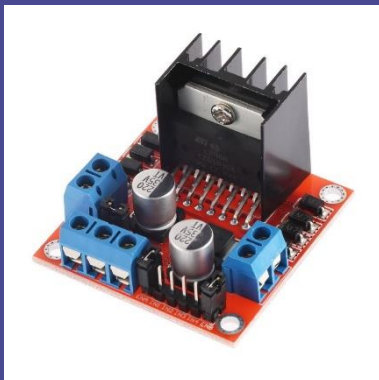

ATMEL AVR ATmega2560

Χαρακτηριστικά

- Μικροελεγκτής 8-bit υψηλής απόδοσης και χαμηλής κατανάλωσης
- Προοδευμένη αρχιτεκτονική RISC (Reduced instruction set computing)
 - 135 εντολές, οι περισσότερες εκτελούνται σε έναν κύκλο ρολογιού
 - 32 x 8 καταχωρητές γενικής χρήσεως
 - Στατική λειτουργία
 - Hardware πολλαπλασιαστής
- Μνήμες δεδομένων και προγράμματος
 - 256K Bytes FLASH (10,000 Write/Erase Cycles)
 - Optional Boot Code Section with Independent Lock Bits
 - 4K Bytes EEPROM (100,000 Write/Erase Cycles)
 - 8K Byte SRAM
 - Programming Lock for Software Security
- JTAG (Joint Test Action Group) IEEE std. 1149.1 Interface for Boundary-scan, on-chip debug, programming of FLASH, EEPROM, fuses, and lock bits
- Ειδικά χαρακτηριστικά
 - Εκκίνηση μικροελεγκτή με σήμα \overline{RESET} και προγραμματιζόμενη ανίχνευση πτώσης τάσης
 - Εσωτερικά ρυθμιζόμενος ταλαντωτής RC
 - Δυνατότητα εξωτερικών και εσωτερικών αιτήσεων διακοπής (IRQ)
 - Έξι διαφορετικές καταστάσεις αναμονής με χαμηλή κατανάλωση

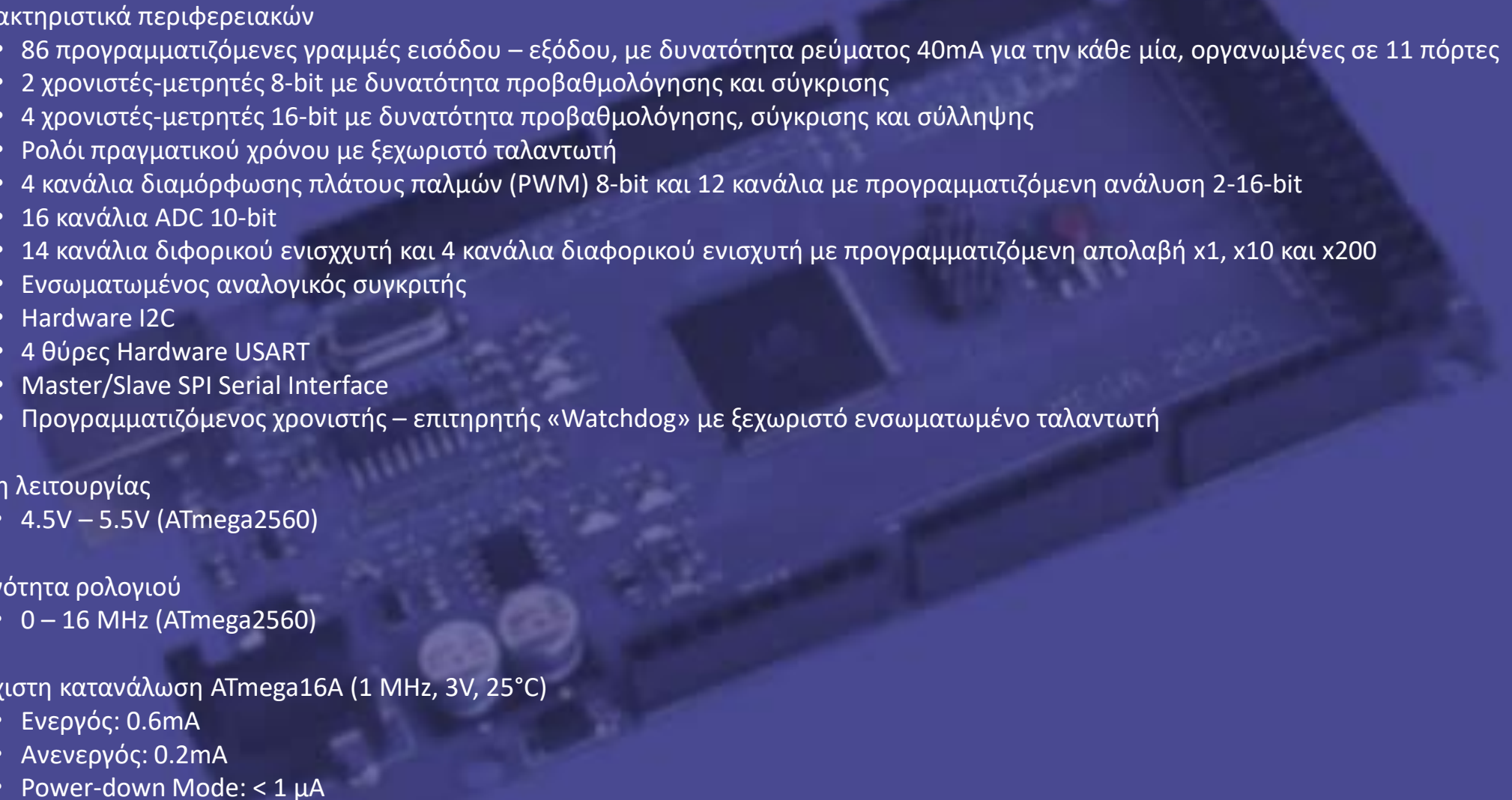
- 
- Χαρακτηριστικά περιφερειακών
 - 86 προγραμματιζόμενες γραμμές εισόδου – εξόδου, με δυνατότητα ρεύματος 40mA για την κάθε μία, οργανωμένες σε 11 πόρτες
 - 2 χρονοστάτες-μετρητές 8-bit με δυνατότητα προβαθμολόγησης και σύγκρισης
 - 4 χρονοστάτες-μετρητές 16-bit με δυνατότητα προβαθμολόγησης, σύγκρισης και σύλληψης
 - Ρολόι πραγματικού χρόνου με ξεχωριστό ταλαντωτή
 - 4 κανάλια διαμόρφωσης πλάτους παλμών (PWM) 8-bit και 12 κανάλια με προγραμματιζόμενη ανάλυση 2-16-bit
 - 16 κανάλια ADC 10-bit
 - 14 κανάλια διαφορικού ενισχυτή και 4 κανάλια διαφορικού ενισχυτή με προγραμματιζόμενη απολαβή x1, x10 και x200
 - Ενσωματωμένος αναλογικός συγκριτής
 - Hardware I2C
 - 4 θύρες Hardware USART
 - Master/Slave SPI Serial Interface
 - Προγραμματιζόμενος χρονοστάτης – επιτηρητής «Watchdog» με ξεχωριστό ενσωματωμένο ταλαντωτή
 - Τάση λειτουργίας
 - 4.5V – 5.5V (ATmega2560)
 - Συχνότητα ρολογιού
 - 0 – 16 MHz (ATmega2560)
 - Ελάχιστη κατανάλωση ATmega16A (1 MHz, 3V, 25°C)
 - Ενεργός: 0.6mA
 - Ανενεργός: 0.2mA
 - Power-down Mode: < 1 μA

ATmega 2560 block diagram

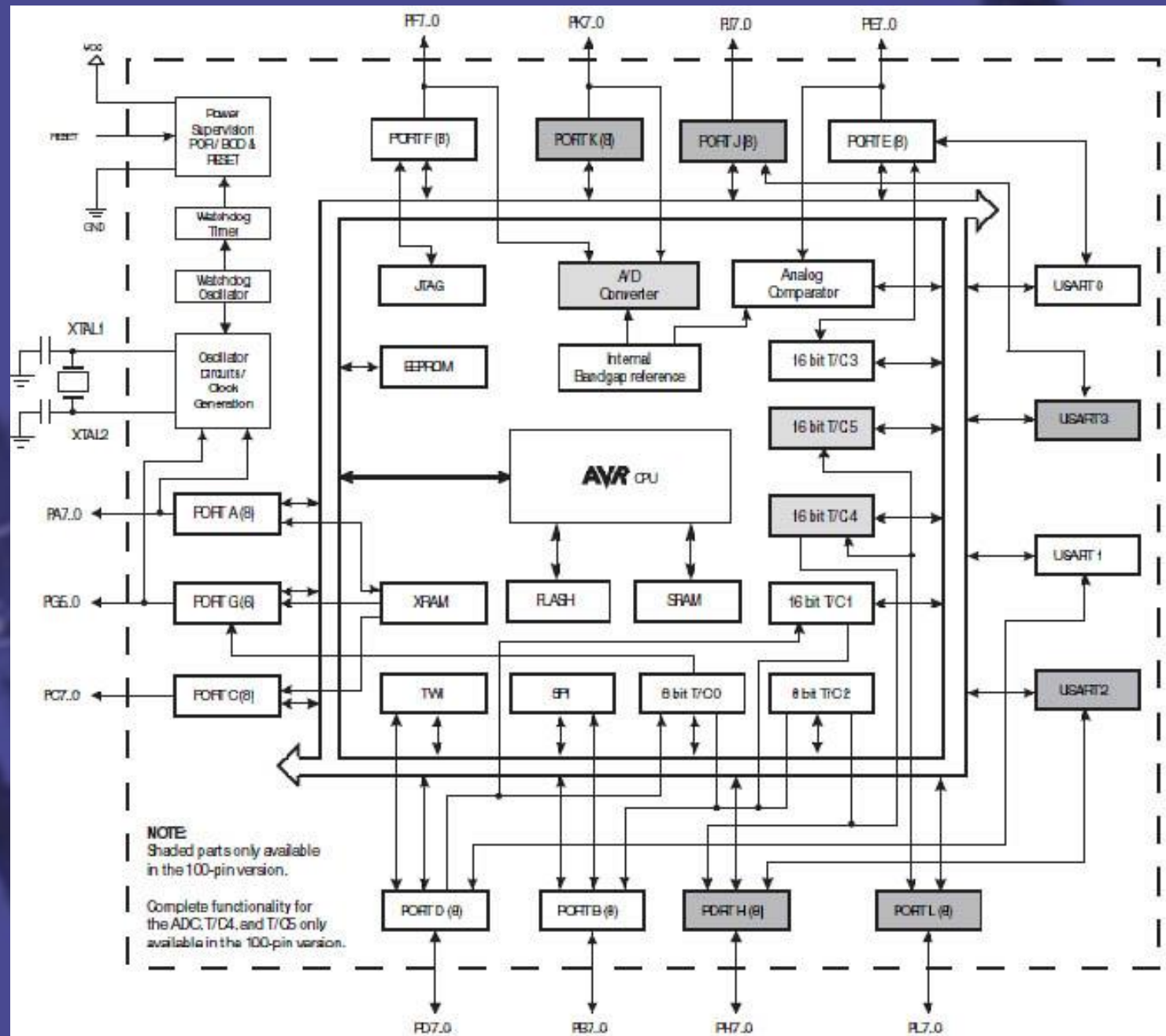

Atmel Studio

- Atmel Studio 7 -> Windows7/8/8.1/10, integrated gcc (Recommended for Windows7 or newer)
- Atmel Studio 6.2 -> WindowsXP/7/8/8.1/10, integrated gcc
- Atmel Studio 4.20/4.19 -> WindowsXP/7, WinAVR gcc plug in, manual configuration*
- Atmel Studio 4.18 -> WindowsXP/7, WinAVR gcc plug in (Recommended for WindowsXP)

Programmer

- Khazama AVR Programmer -> Usbasp
- eXtreme Burner – AVR -> Usbasp
- AvrOspII -> USBISP Connected to COM1-16**
- AvrProg -> USBISP Connected to COM1-4**
(*<http://www.porlidas.gr/ATmegaDev/ATmegaDevEn.htm>)
- PonyProg -> Physical serial or parallel port

Drivers

- Usbasp 2011-05-28
- Prolific 3.3.11.152 v1.2.1 (Prolific, PL2303) -> drivers version issue***
- CH341SER (wch, CH340) -> USB unsigned drivers issue****
- CDM v2.12.00 (ftdi, FT232) -> USB unsigned drivers issue****
(****<http://porlidas.gr/InstDev/InstDevEn.htm>)

Programs

- Programmers Notepad -> WinAVR
- Termite -> Connected COMs, Hex editor http://www.compuphase.com/software_termite.htm
- Putty Terminal -> <http://www.chiark.greenend.org.uk/~sgtatham/putty/download.html>

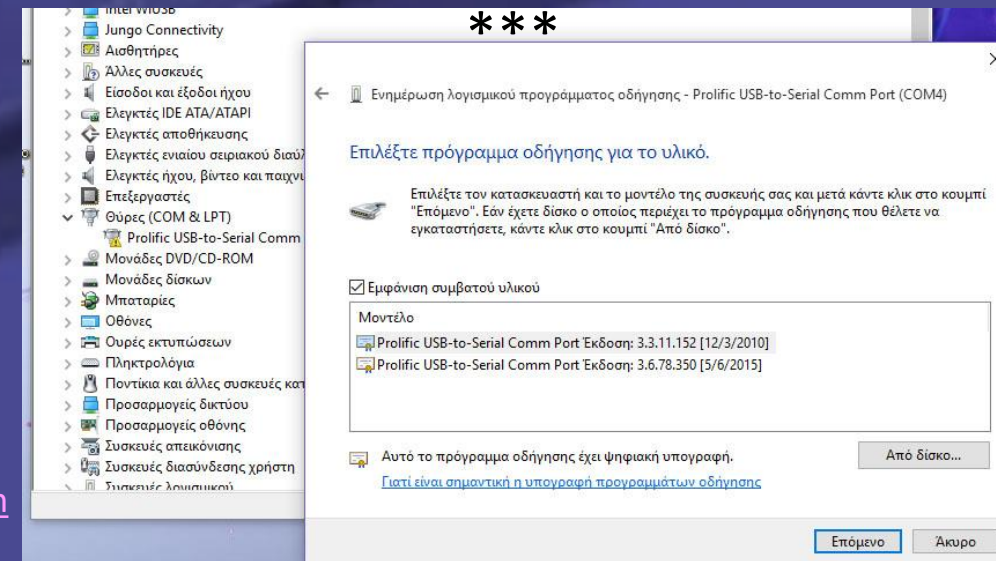
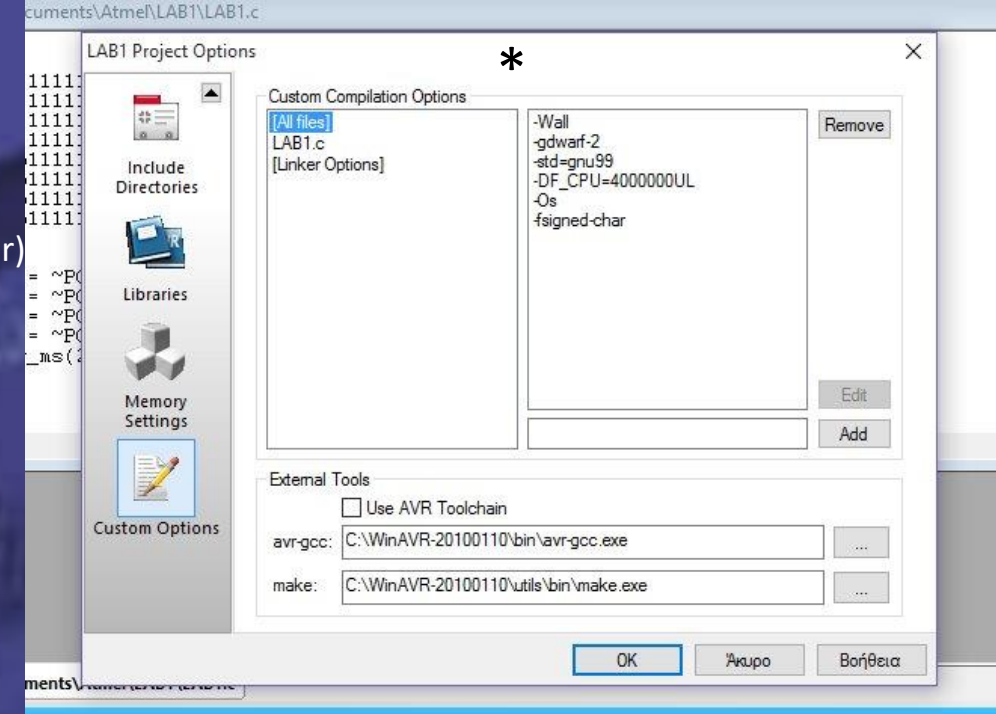

MEGA 2560 Schematic diagram

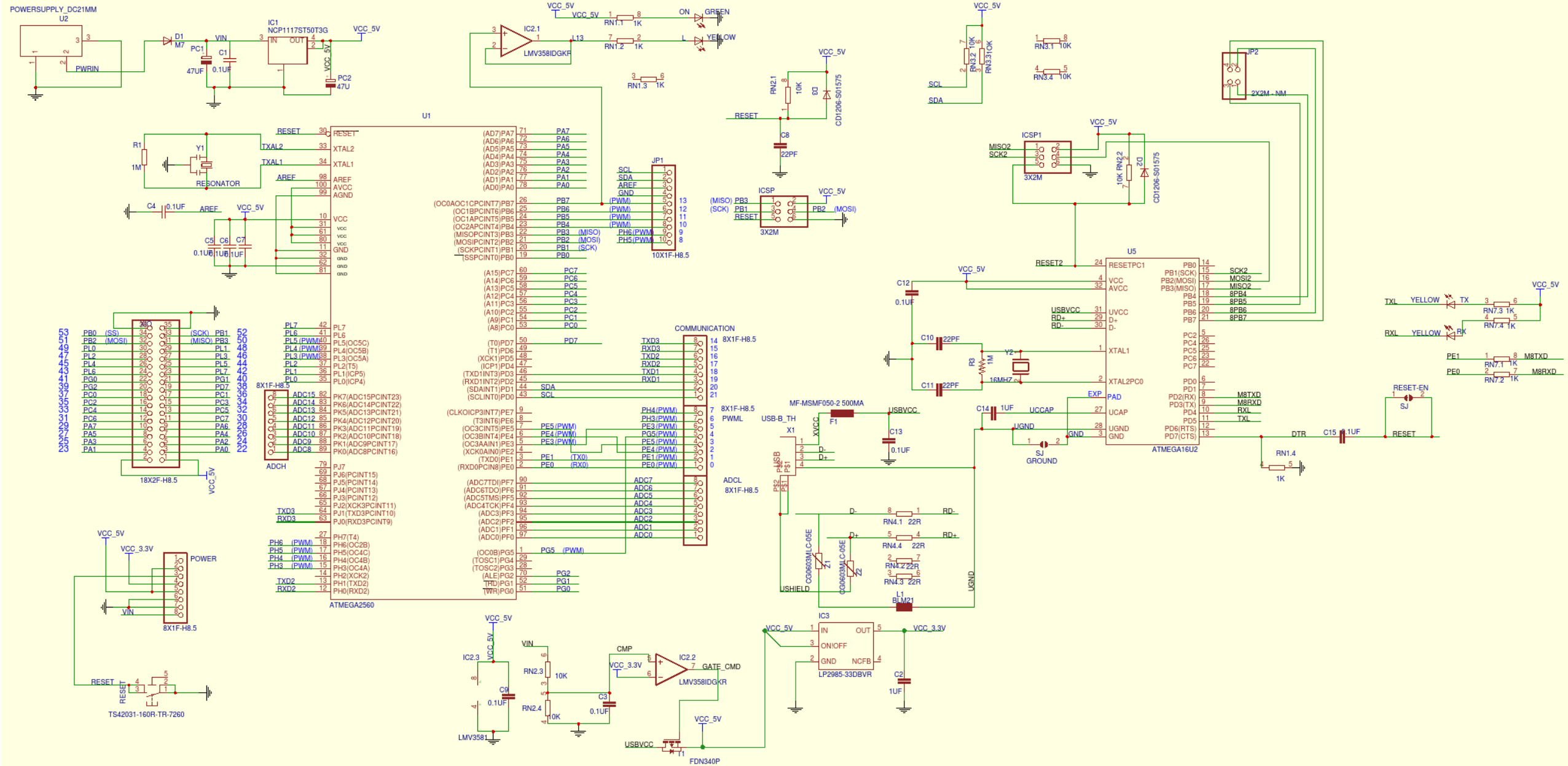

USB ISP USBasp Programmer

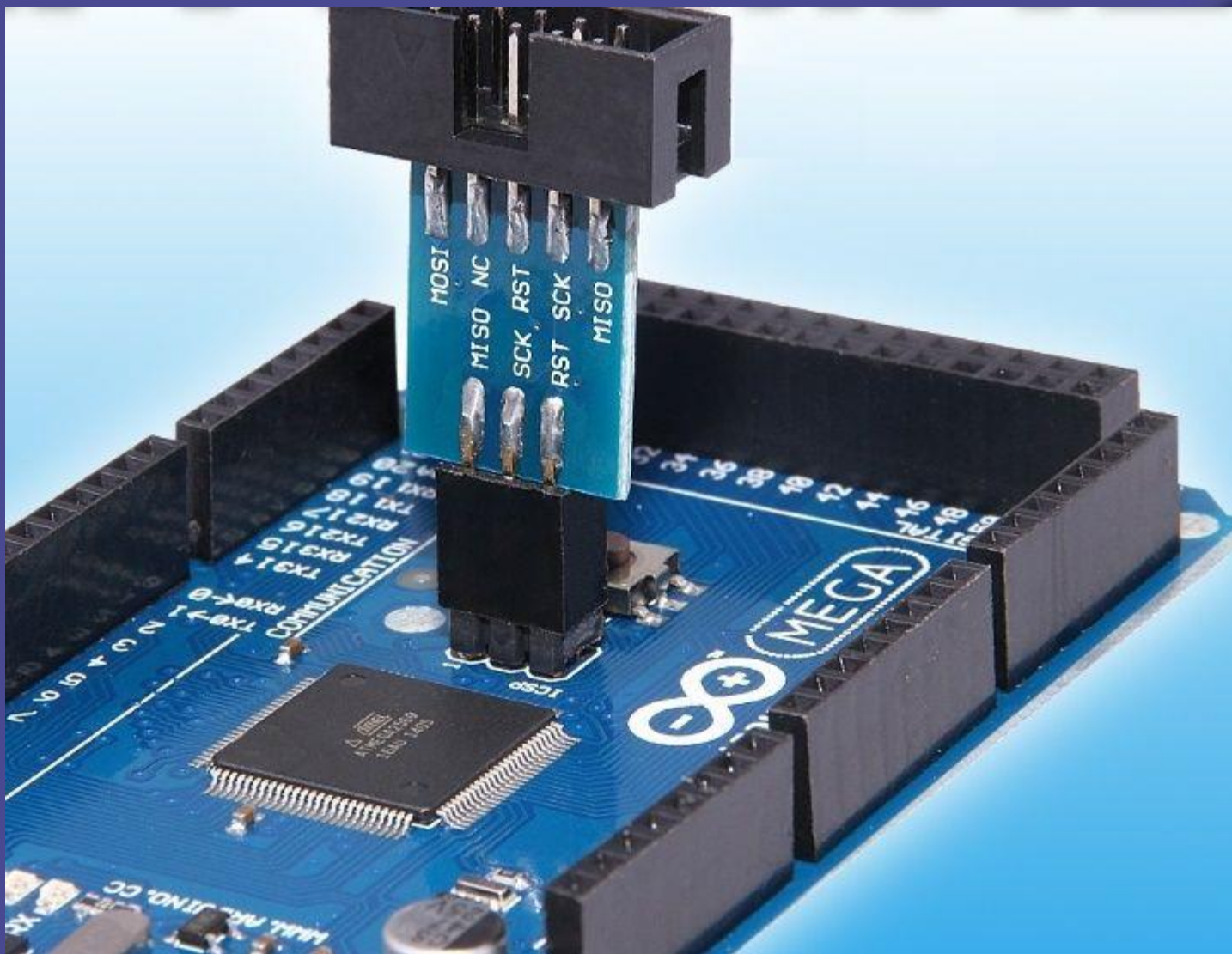

6 Pin

MISO	1	○	○	2	VCC
SCK	3	○	○	4	MOSI
RST	5	○	○	6	GND

1	MISO	Master In, Slave Out
2	VCC	Voltage Common Collector
3	SCK	Serial Clock
4	MOSI	Master Out, Slave In
5	RST	Reset
6	GND	Ground

10 Pin

MOSI	1	○	○	2	VCC
N.C.	3	○	○	4	GND
RST	5	○	○	6	GND
SCK	7	○	○	8	GND
MISO	9	○	○	10	GND

3	N.C.	Not Connected
---	------	---------------

USB ISP USBasp Programmer Schematic diagram

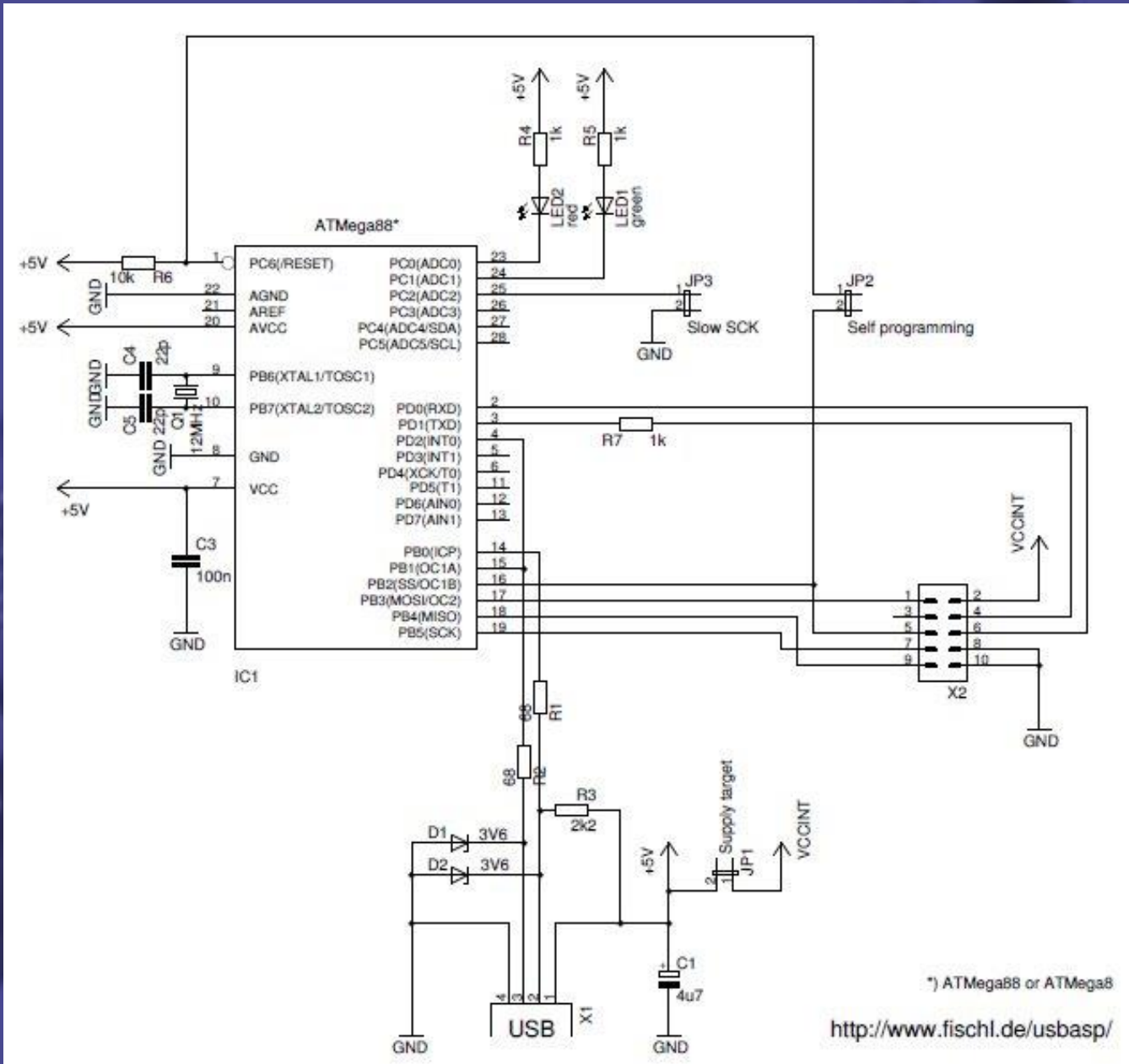

*) ATmega88 or ATmega8

<http://www.fischl.de/usbasp/>

Boards with LEDs, buttons & 4x4 keyboard matrix array buttons

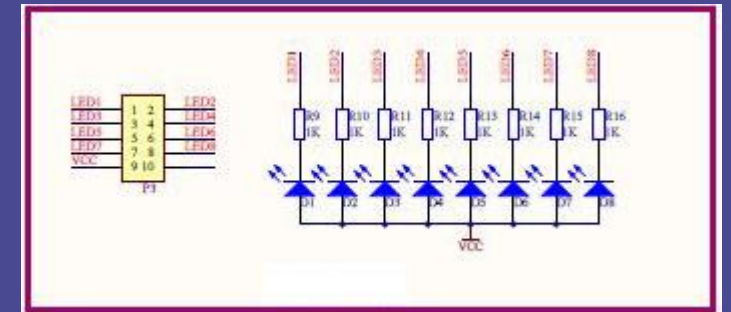
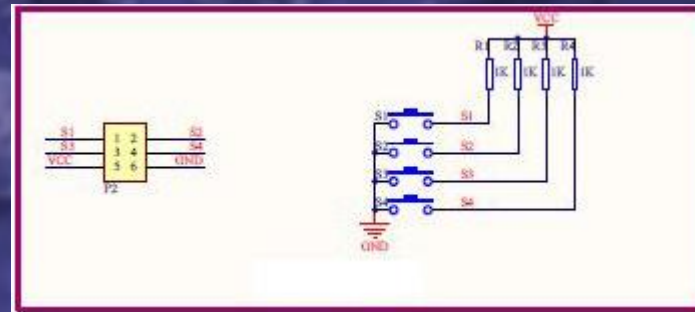
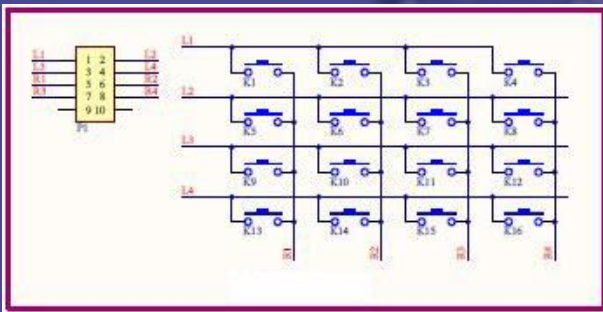
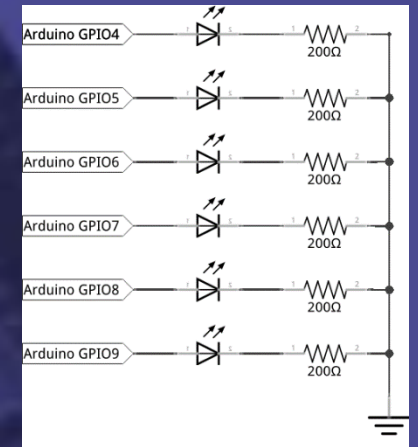
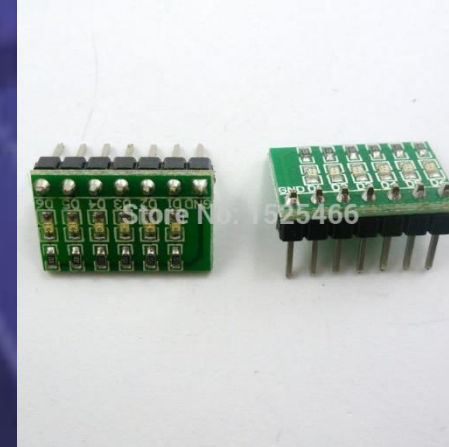
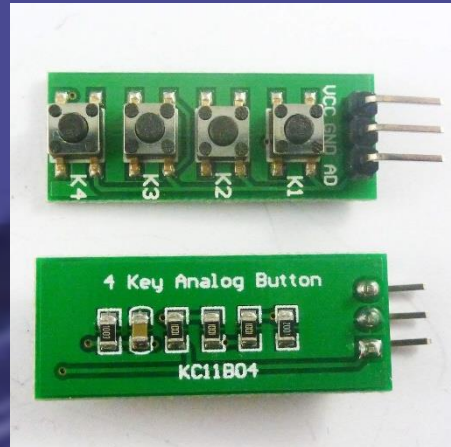
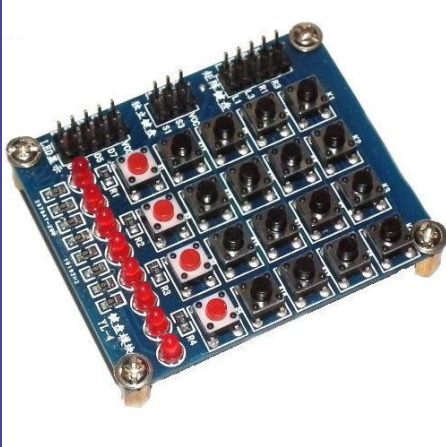

Module Display Character LCD 16x2

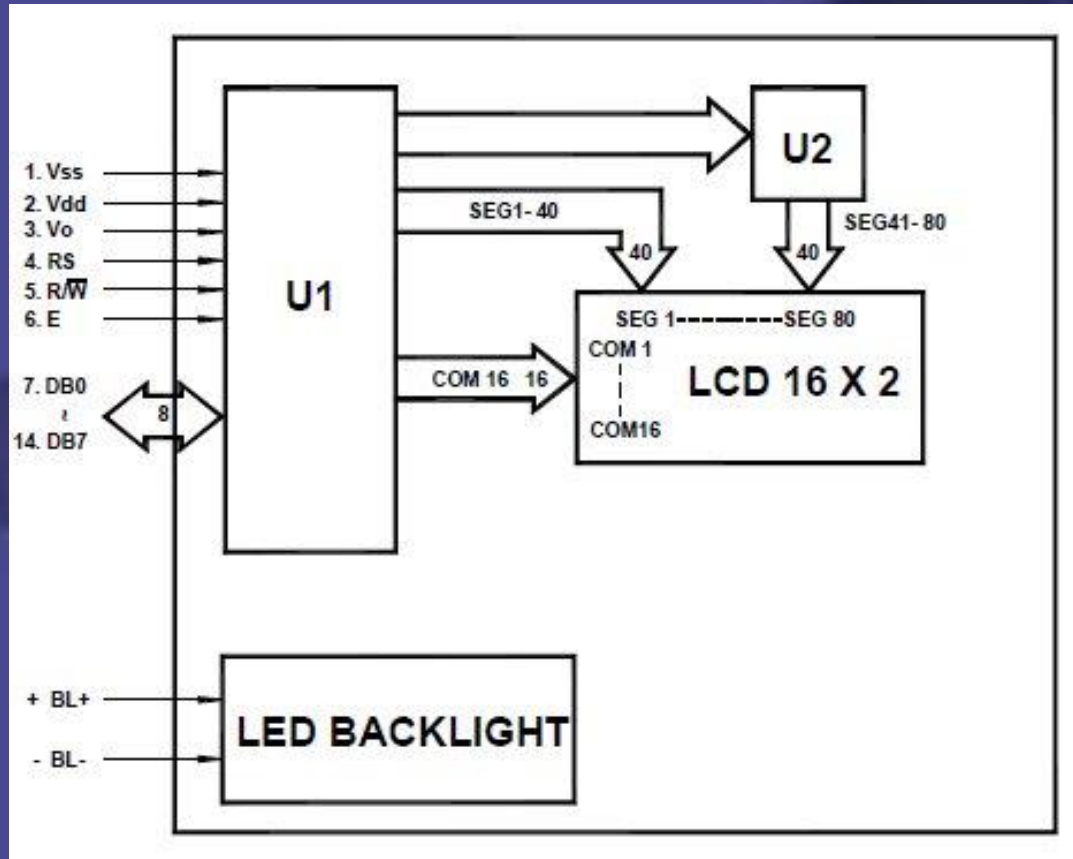

Pin No.	Symbol	Function
1	Vss	Ground
2	Vdd	+5V
3	Vo	LCD contrast adjust
4	RS	Register select
5	R/W	Read / write
6	E	Enable
7	DB0	Data bit 0
8	DB1	Data bit 1
9	DB2	Data bit 2
10	DB3	Data bit 3
11	DB4	Data bit 4
12	DB5	Data bit 5
13	DB6	Data bit 6
14	DB7	Data bit 7
+	BL+	Power Supply for BL+
-	BL-	Power Supply for BL-

USB To RS232 TTL Converter Module PL2303HX

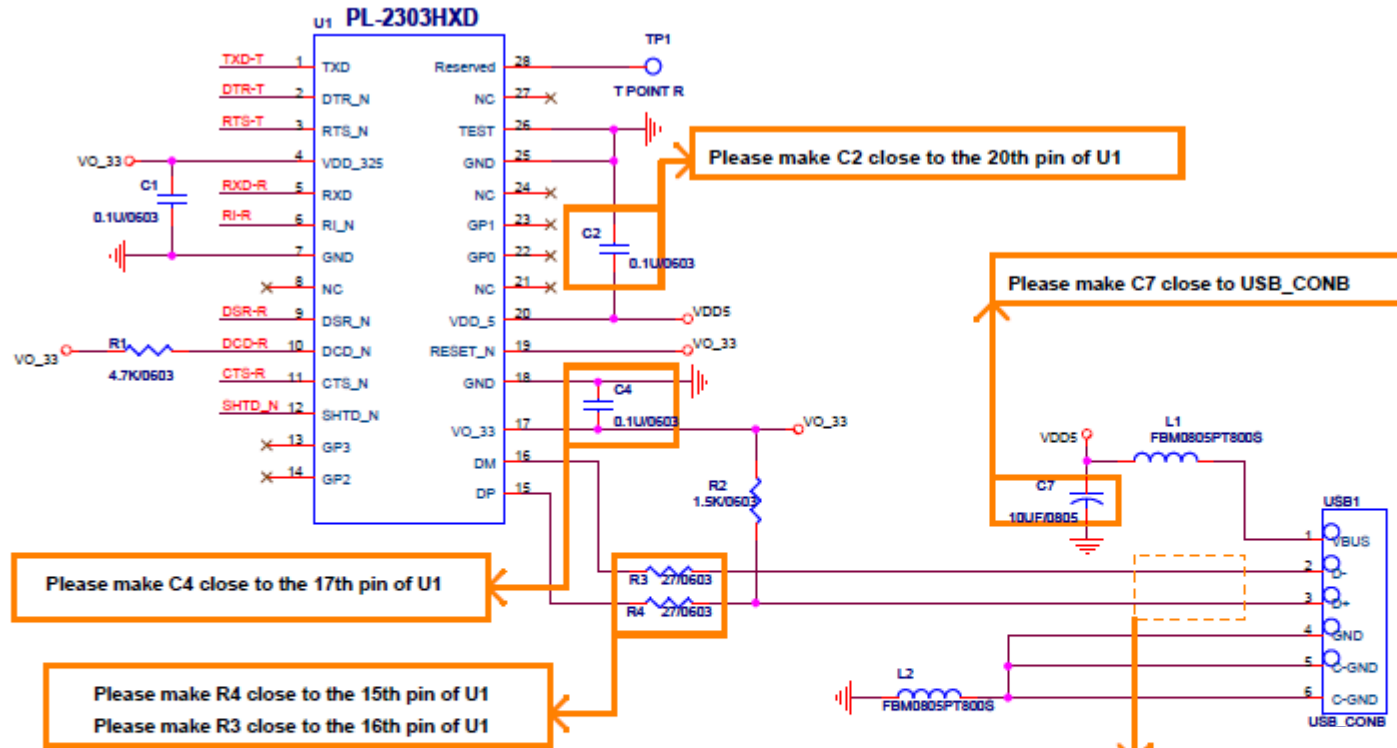

Application for RS-232 Transceiver

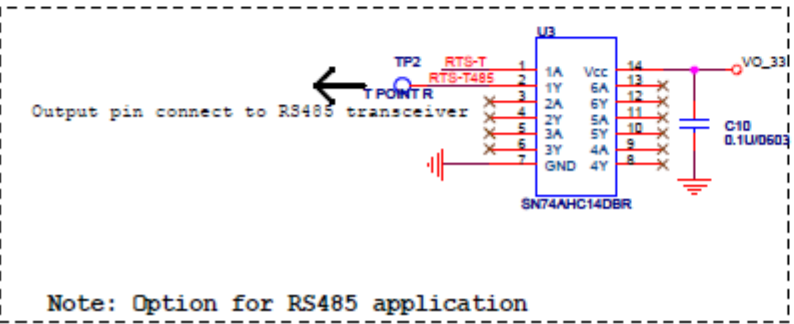
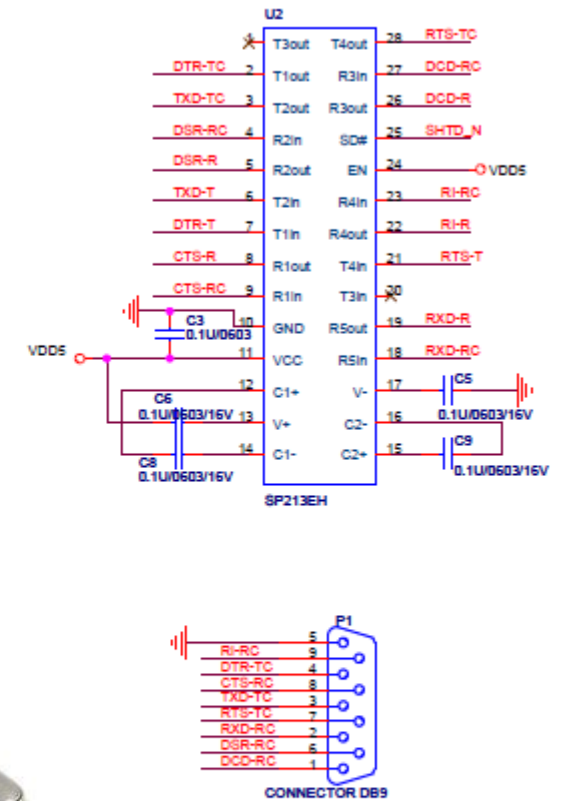

Note: Option for RS485 application

USB To RS232 TTL Converter Module CH340G

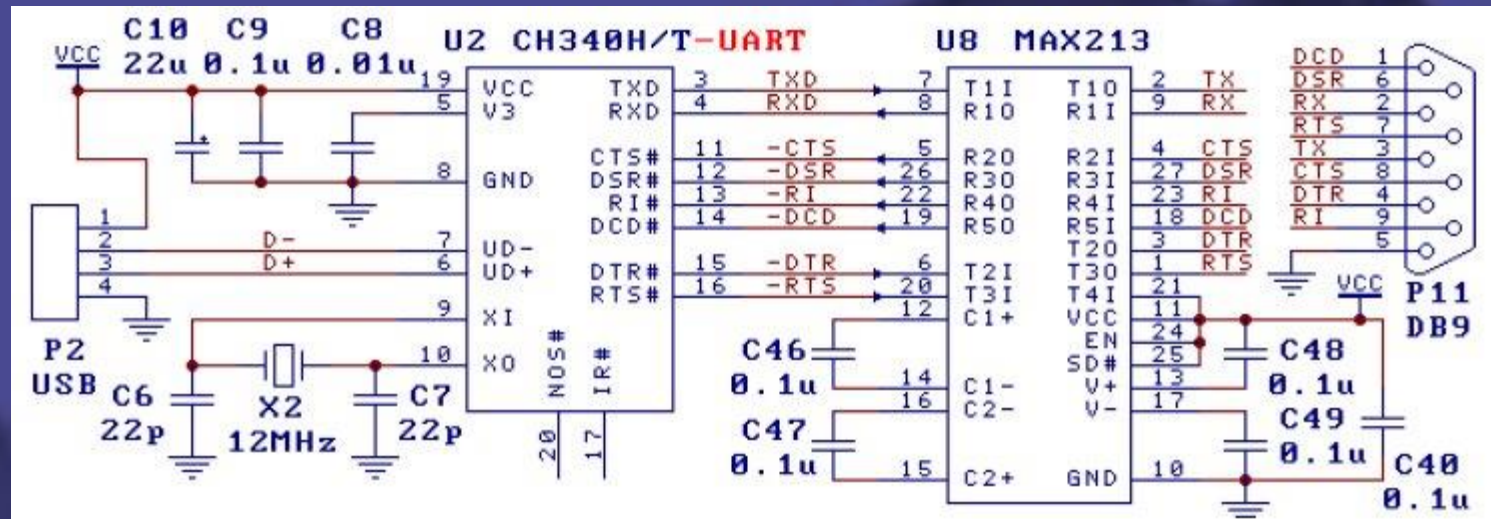

Embedded C for AVR Basic Instructions (Lesson 1)

```
#include <avr/io.h> //AVR BIOS
#include <util/delay.h> //Delay routine

#define F_CPU 4000000UL //MCU Frequency, Definition for Delay routine
#define En 0b00001000 //Definition example

unsigned char i3; //Register example

DDRA = 0b00000000; //Port A all inputs
PORTA = 0b11111111; //Enable pull up resistors to all
DDRB = 0b11111111; //Port B all outputs
PORTB = 0b11011010; //Send 11011010 to outputs

i3 = 0x2F; //Sets i3 value 2F

while (PINA == 0b11101110); //”while” routine & equal example

for (i1 = 0; i1 < 4; i1++) //”for” routine example

_delay_ms (20); //delay example

=, -, +, *, /, <, >, !, ~, &, |, ==, >=, <=, --, ++, //, <<, >>, !=, &&, ||

PORTB = ~PORTB; //NOT
PORTB = PORTB << 1; //SHIFT
PORTB = i3 & 0b11110000; //AND
PORTB = (i3 | 0b11110000); //OR
```

Προτεινόμενη βιβλιογραφία και ιστοσελίδες

Προγραμματίζοντας τον Μικροελεγκτή AVR (Τζιόλα)
C Programming for embedded microcontrollers (Elektor)
Η γλώσσα προγραμματισμού ANSI C (Κλειδάριθμος)

<https://www.microchip.com/>

<http://www.st.com/>

<https://www.arduino.cc/>

<https://eclipse.org/>

<http://www.openstm32.org/>

<http://www.avrfreaks.net/>

<https://github.com/>

<http://winavr.sourceforge.net/>

<http://www.fischl.de/usbasp/>

<http://extremeelectronics.co.in/>

<http://khazama.com/project/programmer/>

<http://www.serasidis.gr/>

<http://www.porlidas.gr/>

©2021-2022 D. Porlidas

